

EMBERTONTM

ELECTRICAL APPLIANCES

PRODUCT CATALOGUE 2021



EMBERTON™

Established 1986

EMBERTON. INVEST FOR YOUR GUEST

“Investing in electrical engineering & technology to improve the safety, reliability & performance of electrical appliances worldwide”

Safety, robustness and reliability are built into all of our professional range of guest room products. Emberton products are a solid investment, adding value to your assets.

With 35 years of history - design, innovation & creativity is our passion and the very heart of Emberton.

Working closely with a panel of experienced hoteliers helps us to understand the trends, habits & behavior of guests, perfecting our product innovations all the way from development to production.

Emberton products are available through a global network of specialist hotel supply distributors, with professional support and service to match the expectation of the Emberton brand.





DUAL SAFE™, AN EMBERTON PROPRIETARY ELECTRICAL SAFETY SYSTEM, IS INTEGRATED INTO THE ELECTRICAL CIRCUIT TO DETECT TEMPERATURE

DUAL SAFE™ THERMOFUSE TECHNOLOGY **WHAT DOES IT DO?**

DUAL SAFE™ prevents electrical appliances catching fire due to overheating.

DUAL SAFE™ THERMOFUSE TECHNOLOGY **HOW DOES IT WORK?**

DUAL SAFE™ uses an organic, thermo-sensitive material, remarkably sensitive to abnormally high temperatures. Upon sensing critical heat levels, DUAL SAFE™ activates and the electrical current will be interrupted immediately and permanently.

Working independently from and in addition to the thermostat, DUAL SAFE™ system immediately cuts power to an appliance when temperatures reach critical levels.

DUAL SAFE™ THERMOFUSE TECHNOLOGY **WHAT DOES IT DO?**

In most electrical appliances, the thermostat is the only safety system. Thermostats are very sensitive components and can become faulty or damaged by misuse. If the thermostat fails, it's easy for the appliance to catch fire.

DUAL SAFE™ acts as an additional safety system, preventing risk of an accidental fire when using an EMBERTON DUAL SAFE™ electrical appliance.

INDEX

KETTLES

05-10

Evesham
Malvern
Corsham
Guildford



WELCOME TRAYS

11-16

Heywood Slate
Cambourne Plus
Tongwell
Walton
Halstead



HAIRDRYERS

17-24

Thames
Salford Deluxe
Harrow
Marlow
Mursley (Hairdryer Holder)
Lathbury (Hairdryer Bag)



IRONS

25-28

Croft
Hertford
Yardley



TOUGH IRONING BOARDS

29-30

Rothwell
Moulton
Sherington



IRONING CENTRES SAFETY & STORAGE

31-36

Bromham
Kingsmead
Elstow
Stagsden
Stroud
Somerton
Sandhurst (Holder)
Hyde (Holder)



ACCESSORIES & ROOM ESSENTIALS

37-43

Bodmin Multi-Function Alarm Clock
Woburn Push Power Bathroom Scale
Fairford Bathroom Scale
Ashton Bathroom Scale



SPECIFICATIONS

44- 54

Technical Data
Dimensions
Packaging Details



KETTLES

WELCOME
TRAYS

HAIRDRYERS

IRONS

TOUGH IRONING
BOARDS

IRONING CENTRES SAFETY & STORAGE

ACCESSORIES &
ROOM ESSENTIALS

SPECIFICATIONS



KETTLES

Evesham

Double Wall Safety Insulated Kettle 1.0L

- ➔ Boil Aware 360 : active BLUE boil-on LED pilot ALERT light encircles complete body with 360° glow for added safety awareness during boiling
- ➔ Double Layer Safety Insulation - reduces surface heat to help prevent scalding & heat loss
- ➔ Illuminated Water window - clear and brightly lit blue LED for greater clarity of water level
- ➔ Advanced Technology Isolation Boil Dry
- ➔ Dual Safe – Thermostat & Latest Technology Internal Fuse
- ➔ High Grade SS304 Stainless Steel Body & Heat Plate
- ➔ ECO saves Water and Energy
- ➔ Concealed Heating Element for Easy Cleaning
- ➔ Auto Steam Switch off
- ➔ Auto Off Power Indicator Light
- ➔ Hinged Trigger Style Locking lid
- ➔ Available in EU & BS plug variants

Specifications

Power	1500-1800W (220-240V, 50-60Hz)
Dimensions	220 x 143 x 220mm
Overall Height	220mm
Top Diameter	88mm
Base Diameter	143mm
Certification	CE, CB, RoHS & GS Approved
Weight	930g



Double Layer Safety Insulation



360° Swivel



Registered Design



Design Protected by
International Registered Designs
& Patents Pending
© Emberton Group Inc



Available in BLACK

Evesham

Double Wall Safety Insulated Kettle 1.0L



Available in BLACK

Malvern Brushed Stainless Steel Kettle 0.5L

- ➔ Advanced Technology Isolation Boil Dry
- ➔ Dual Safe – Thermostat & Latest Technology Internal Fuse
- ➔ Water Level Gauge Window
- ➔ ECO saves Water and Energy
- ➔ Concealed Heating Element for Easy Cleaning
- ➔ Auto Steam Switch off
- ➔ Auto Off Power Indicator Light
- ➔ Hinged Trigger Style Locking lid
- ➔ Available in EU & BS plug variants

Specifications

Power	800-950 Watt (220-240V, 50-60Hz)
Dimensions	190 x 150 x 185mm
Overall Height	185mm
Top Diameter	90mm
Base Diameter	143mm
Certification	CE, CB, RoHS & GS Approved
Weight	770g



High Grade SS304
Stainless Steel Body
& Heat Plate



Cordless 360° Swivel



Registered Design



Design Protected by
International Registered Designs
& Patents Pending
© Emberton Group Inc



Available in BLACK

Corsham Brushed Stainless Steel Kettle 1.0L

- ➔ Advanced Technology Isolation Boil Dry
- ➔ Dual Safe – Thermostat & Latest Technology Internal Fuse
- ➔ Water Level Gauge Window
- ➔ ECO saves Water and Energy
- ➔ Concealed Heating Element for Easy Cleaning
- ➔ Auto Steam Switch off
- ➔ Auto Off Power Indicator Light
- ➔ Hinged Trigger Style Locking lid
- ➔ Available in EU & BS plug variants

Specifications

Power	800-950 Watt (220-240V, 50-60Hz)
Dimensions	190 x 143 x 209mm
Overall Height	209mm
Top Diameter	90mm
Base Diameter	143mm
Certification	CE, CB, RoHS & GS Approved
Weight	790g



High Grade SS304
Stainless Steel Body
& Heat Plate



Cordless 360° Swivel



Registered Design



Design Protected by
International Registered Designs
& Patents Pending
© Emberton Group Inc



Guildford Premium Hotel Kettle 0.8L

- ➔ Only 950W Power Consumption Average
- ➔ Advanced Technology Isolation Boil Dry – 100% OFF Non-Recycle
- ➔ SS 304 Stainless Steel Heat Boiling Plate
- ➔ Water Level Gauge Window
- ➔ Durable Trigger Style Spring Assisted Locking Lid
- ➔ Easy Water Pour & Flow
- ➔ Easy Wipe Clean Plastic Interior
- ➔ Concealed Heating Element for Easy Cleaning
- ➔ Auto Steam Switch off
- ➔ Auto Off Power Indicator Light
- ➔ Washable Filter

Specifications

Power	870 - 1035W (220-240V, 50-60Hz)
Dimensions	187 x 139 x 180mm
Overall Height	180mm
Top Diameter	90mm
Base Diameter	139mm
Certification	CE, CB & GS Approved
Weight	605g



SS 304
Stainless Steel Base



360° Swivel Cordless



Highest Quality &
Sturdy Body & Lid





Available in WHITE

Guildford
Premium Hotel Kettle 0.8L



WELCOME TRAYS

Heywood Slate

100% Melamine Series

**MATT. FINE GRAINED.
UNIQUE. ELEGANT. REFINED.**

Our HEYWOOD SLATE series offers a unique and creative slate effect - a fine grained MATT finish with the robust material benefits of stain, scratch & heat resistant 100% melamine.

The slender, elegant & stylish design gracefully compliments your guest room - blending perfectly with rooms featuring timber, stone or steel.

- ➔ Innovative & Unique Synthetic Slate Effect Series - 100% Melamine
- ➔ Slimline - Elegant & Refined, Stylish & Luxurious
- ➔ Appearance of Natural Slate - perfect blend to compliment rooms featuring timber, stone and steel

Specifications

	MAIN TRAY	SERVICE TRAY	AMENITY HOLDER
Dimensions	358 x 258 x 10mm	235 x 110 x 10mm	145 x 75 x 40mm
Material	Melamine	Melamine	Melamine
Weight	500g	135g	130g



MAIN TRAY



SERVICE TRAY



AMENITY HOLDER





Heywood Slate

Welcome Tray with Service Tray & Amenity Holder

(Kettle, Cups & Ingredients not included)



Cambourne Plus

Drawer Welcome Tray with Protective Spillage Tray

- ➔ Eco-Friendly First Grade Bamboo
- ➔ Removable Tray Prevents Spillage & Protects Surface
- ➔ Elegant Soft Contour Design
- ➔ Stores Ingredients Neatly & Dust Free
- ➔ Drawer stores condiments 57mm high
- ➔ Certified Food Grade
- ➔ Robust & Sturdy Construction
- ➔ Easy to clean – smooth surface to wipe clean
- ➔ Neat & Tidy Condiments Presentation
- ➔ Easy Slide In & Out Multiple Compartments Drawer
- ➔ Designed to fit **EMBERTON™** Kettles

Specifications

Dimensions	272mm x 194mm x 85mm
Material	First Grade Bamboo
Weight	1450g



Space Saving Ultra Compact



Removable Drawer for Easy Cleaning



CERTIFIED
FOOD
GRADE



(Kettle, Cups & Ingredients not included)



Tongwell Bamboo Welcome Tray

- ➔ Eco Friendly Bamboo
- ➔ Integrated Kettle to Deter Theft
- ➔ Elegant and Compact Design
- ➔ Easy Wipe-Clean Curved Contour Edges
- ➔ First Grade Bamboo Material
- ➔ Space Saving, Modular Design
- ➔ Food Grade Safety
- ➔ Designed to fit **EMBERTON™** Kettles

Specifications

Dimensions	260mm x 260mm x 30mm
Material	First Grade Bamboo
Weight	850g



Available in Black



Available in Mahogany



(Kettle, Cups & Ingredients not included)



Walton ABS Welcome Tray

- ➔ First Grade ABS Material With Wood Grain Effect
- ➔ Integrated Kettle to Deter Theft
- ➔ Removable Perforated Stainless Steel Drip tray to Prevent Spillage
- ➔ All in One Design with Cavities for Sachets, Spoon & Cups
- ➔ Easy Wipe-Clean Curved Contour Edges
- ➔ Space Saving, Modular Design
- ➔ Wood Grain Handfeel to Reduce Finger Marks
- ➔ Tray Accomodates Kettle Base Controller of 143mm Diameter
- ➔ Designed to fit **EMBERTON™** Kettles

Specifications

Dimensions	460mm x 225mm x 35mm
Material	ABS
Weight	738g



CERTIFIED
FOOD
GRADE



Attractive Design and Easy to Clean



Perforated Stainless Steel Drip Tray



Designed to fit **EMBERTON™** Kettles

(Kettle, Cups & Ingredients not included)



Halstead Integrated Kettle Welcome Tray

- ➔ Integrated Kettle Slot to Deter Theft
- ➔ Robust & Durable Stain, Heat & Scratch Resistant Melamine
- ➔ Space Saving Ultra Compact – uses less space
- ➔ Certified Food Grade Materials
- ➔ Elegant Soft Contour Design
- ➔ Neat & Tidy Condiments Presentation
- ➔ Easy Wipe Clean Surface & Contoured Compartments
- ➔ Robust & Sturdy Construction
- ➔ Tray accommodates kettle base controller of 143mm Diameter
- ➔ Designed for use with all **EMBERTON™** kettle types

Specifications

Dimensions	262mm x 262mm x 30mm
Material	Melamine
Weight	610g



Available in WHITE



Elegant Soft Contour Design



CERTIFIED
FOOD
GRADE



(Kettle, Cups & Ingredients not included)



HAIRDRYERS

Thames

Hotel Safety 2000W Hairdryer Soft Touch Finish with Wall Mount Option

- ➔ Hotel Safety ON/OFF Press Switch Saves Energy & Safe
- ➔ Dual Safe – Thermostat & Latest Technology Internal Fuse
- ➔ Ceramic Ionic for Smooth Shiny Result
- ➔ Luxurious Soft Touch Finish
- ➔ Powerful 2000 Watt DC Motor
- ➔ 2 Speed/2 Heat & Cool Settings
- ➔ Removable Filter Cover & Safety Mesh Blade Cover
- ➔ Complete with Air-Flow Concentrator for Perfect Styling & Drying
- ➔ Safety Thermostat Over-heating circuit protection
- ➔ Ergonomic Non-Slip Contoured Handle for comfortable use and hold
- ➔ Stylish & Elegant Design
- ➔ Insulated Motor to reduce noise
- ➔ Generous 350 cm Long Extendable COIL cord
- ➔ Built in Hanging Loop
- ➔ Available in EU & BS plug variants

Specifications

Power	220-240V, 50/60Hz
Wattage	1800-2200W
Dimensions	240mm x 85mm x 280mm
Certification	CE, CB, ROHS & GS Approved
Weight	615g



For BEDROOM use only.
NOT for use in BATHROOM
or PUBLIC AREAS



Soft Touch Finish



Safety ON/OFF Press Switch



Specially Constructed Coil to Retain Shape



Wall Holder Option

Thames
Hotel Safety 2000W Hairdryer
Soft Touch Finish with Wall Mount Option



Converts to Wall Mounted with HOLDER option

Salford Deluxe

Hotel Safety 1800W Hairdryer Soft Touch Finish & Chrome with Wall Mount Option

- ➔ Hotel Safety ON/OFF Press Switch to save energy & safe
- ➔ Dual Safe – Thermostat & Latest Technology Internal Fuse
- ➔ Ceramic Coating with Tourmaline for Smooth Shiny Result
- ➔ Wall Holder Option with matching chrome and black trim and built in anti-theft cable tracks
- ➔ Super Coil Cord with bounce back even after intensive stretch
- ➔ Luxurious Soft Touch Finish with Elegant Chrome Barrel & Filter Cover
- ➔ Safety Thermostat Over-Heating circuit protection
- ➔ Complete with Air-flow Concentrator for Perfect Styling and Drying
- ➔ Generous length cable extends to 250cm to accommodate power outlets
- ➔ Ergonomic Non-Slip Contoured Handle for comfortable use and hold
- ➔ Built in Hanging Loop
- ➔ Available in EU & BS plug variants

Specifications

Power	220-240V, 50/60Hz
Wattage	1800W
Dimensions	240mm x 90mm x 250mm
Certification	CE, CB, ROHS & GS Approved
Weight	600g



2 Speed / Heat settings



Safety ON/OFF Press Switch



Specially Constructed Coil to Retain Shape



For BEDROOM use only.
NOT for use in BATHROOM
or PUBLIC AREAS



Harrow

1600W Folding Hairdryer

- ➔ Hotel Safety ON/OFF Press Switch to save energy & safe
- ➔ Dual Safe – Thermostat & Latest Technology Internal Fuse
- ➔ Ceramic Coating with Tourmaline for Smooth Shiny Results
- ➔ Complete with Air-flow Concentrator for Perfect Styling and Drying
- ➔ Cool Shot Switch feature
- ➔ Insulated motor to reduce noise
- ➔ Generous cord length 200cm long
- ➔ Removable Filter for easy cleaning
- ➔ Ergonomic Non-slip contoured handle for comfortable use
- ➔ Built in Hanging Loop
- ➔ Available in EU & BS plug variants



Folds for convenience



2 Speed/Heat settings

Specifications

Power	AC220-240V, 50/60Hz
Wattage	1400-1600W
Dimensions	140mm x 77mm x 231mm
Certification	CE, CB, ROHS & GS Approved
Weight	390g





HAIRDRYERS

Marlow

Hotel Safety 1875W Foldable Hairdryer with Wall Mount Option

- ➔ Dual Safe – Thermostat & Latest Technology Internal Fuse
- ➔ Powerful 1875W DC Motor
- ➔ Ceramic Coating with Tourmaline for Smooth Shiny Result
- ➔ COOL SHOT Button Blasts cool air to help set your style
- ➔ Soft Touch Matt Finish - Toughened Coating
- ➔ Generous 300 cm Long Extendable COIL cord
- ➔ Removable Filter Cover for Easy Cleaning
- ➔ Complete with Air-flow Concentrator for Perfect Styling and Drying
- ➔ Insulated Motor to Reduce Noise
- ➔ Ergonomic Non-Slip Contoured Handle for comfortable use
- ➔ Safety Thermostat Over-heating circuit protection
- ➔ Built in Hanging Loop
- ➔ Available in EU & BS plug variants

Specifications

Power	AC220-240V, 50/60Hz
Wattage	1800-2000W
Dimensions	250mm x 95mm x 270mm
Certification	CE, CB, ROHS & GS Approved
Weight	695g



Folds for convenience



2 Speed/3 Heat & Cool Settings



For BEDROOM use only.
NOT for use in BATHROOM
or PUBLIC AREAS



Wall Holder Option

Marlow
Hotel Safety 1875W Foldable Hairdryer



Available in
WHITE or BLACK

Mursley

Wall Mounted Hairdryer Holder
with Anti-Theft Cable Track

- Built in Anti-theft Cable Tracks
- Easily Mounts on Wall
- Soft Glide Lining

Specifications

Dimensions	93mm x 74mm x 50mm
Weight	50g

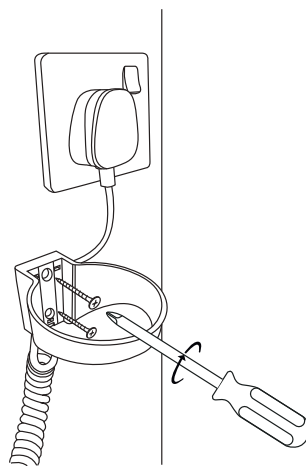

Easily Mounts On Wall



Anti-theft Lock Cable Track



Soft Glide Lining





Lathbury Hairdryer Bag

- ➔ High Quality Black Soft Velvet
- ➔ Silver Thread Embroidery
- ➔ Strong PP Drawstring
- ➔ Perfect for keeping hairdryers scratch & dust free

Specifications

Dimensions	400mm x 300mm
Weight	66g



Silver Thread Embroidery



Strong PP Drawstring





IRONS

Croft

2000W Hotel Safety Steam Iron

- DUAL SAFE Thermostat & Latest Technology Internal Fuse
- ECO Auto Off Function for Extra Energy Saving & Environmental Protection
- Special Anti-drip feature to prevent water dripping through steam outlets after water cools
- FUSION Anti-Leak - New water tank assembly method using a wire frame and latest thermo-weld technology to prevents tank fracture
- Motion Sensor Auto-Cut Off -30 Seconds unattended on soleplate and 5 minutes upright
- Super long 300cm cable
- Anti-calc to remove the limescale build up
- New thermostat technology uses a silver coating for more accurate heat settings
- Auto Off Indicator Light
- Cable cord guard tested to 20,000 cycles to ensure cable safety
- 300 ML Capacity water reservoir
- LED Green & Red In-Use Indicator Light
- Includes Refill Beaker
- UK or EU Plug variants



Powerfull Burst of Steam & Spray Vertical & Horizontal



Easy Steam Finger Release Button

Specifications

Power	AC220-240V, 50/60Hz
Wattage	2000W
Capacity	300ML
Colour	Black / Grey
Plate Size	220mm x 120mm
Soleplate	Ceramic
Certification	CE, CB, RohS & GS Approved
Weight	1160g





Ceramic Soleplate

Croft 2000W Hotel Safety Steam Iron



Available in **WHITE**

Hertford
1600W Hotel Safety Steam Iron

- ➔ DUAL SAFE Thermostat & Latest Technology Internal Fuse
- ➔ Motion Sensor Auto-Cut Off –30 Seconds unattended on soleplate and 5 minutes upright
- ➔ ECO Auto Off Function for extra Energy Saving & Environmental Protection
- ➔ FUSION Anti-Leak - New water tank assembly method using a wire frame and latest thermo-weld technology to prevents tank fracture
- ➔ Special Anti-drip feature to prevent water dripping through steam outlets after water cools
- ➔ Extra long 250cm cable
- ➔ Auto Off Indicator Light
- ➔ Cable cord guard tested to 20,000 cycles to ensure cable safety
- ➔ LED Green & Red In-Use Indicator Light
- ➔ Includes Refil Beaker
- ➔ UK or EU Plug variants



Powerfull Burst of Steam & Spray Vertical & Horizontal



Narrow Front Tip



Self Clean Feature

Specifications

Power	AC220-240V, 50/60Hz
Wattage	1600W
Capacity	250ML
Colour	Black / Grey
Plate Size	206mm x 113mm
Soleplate	Non-Stick
Certification	CE, CB, RohS & GS Approved
Weight	982g





Yardley

1200W Hotel Safety Dry Iron

- Dual Safe – Thermostat & Latest Technology Internal Fuse
- Exclusive Safety 5 minutes Auto Off Motion Sensor
- Uniform Heat Distribution for Smooth Ironing
- Tough Non Stick Soleplate
- Motion Sensor Auto-Cut Off Safety – 30 Seconds unattended on soleplate and 5 minutes upright
- ECO Auto Off Function for Energy Saving & Environmental Protection
- Operating Light with Cut-Out Indicator
- Generous 250 cm Durable Cord
- Cable cord guard tested to 20,000 cycles to ensure cable safety
- Gloss Skirt with Attractive Black & Grey Design
- UK or EU Plug variants



Large temperature adjustment dial



Overheat safety protection



Narrow Front Tip

Specifications

Power	AC220-240V, 50/60Hz
Wattage	1200W
Colour	Black / Grey
Plate Size	200mm x 110mm
Soleplate	Non-Stick
Certification	CE, CB, RohS & GS Approved
Weight	745g





IRONING BOARDS



Ironing Board Engineered Series

Our super strong series of tough ironing board is a result of extensive research and development with industry professionals and hotels., working closely to identify the needs, habits and often rough treatment of hotel ironing boards.

Rugged & Durable - We have combined a rugged frame with heavy duty metal components and robotic welds to withstand guests' tough use.

THE ULTIMATE STRENGTH IN IRONING BOARDS

- ➔ Tube Frame Legs 38mm/28mm
- ➔ Strong Double Handle Height Adjustment Lever
- ➔ Steam Flow Metal Mesh Top
- ➔ 2mm Foam and 5mm Felt Combination Padding
- ➔ Smooth Binding Edges to Withstand Fraying
- ➔ Cover Material : Cotton with Felt Underlay
- ➔ Cover Colour : Charcoal Grey
- ➔ Frame Colour : Silver Grey

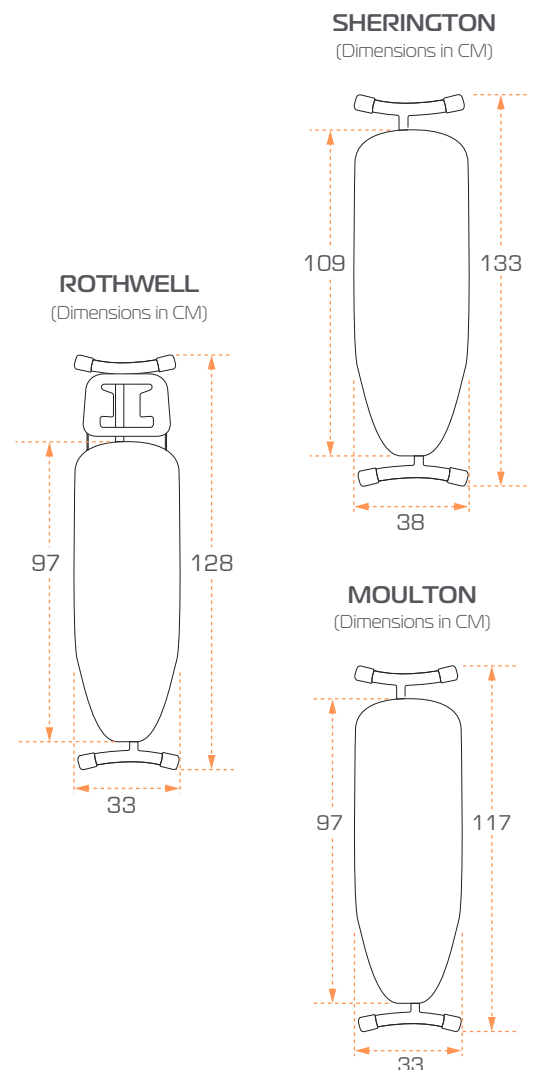

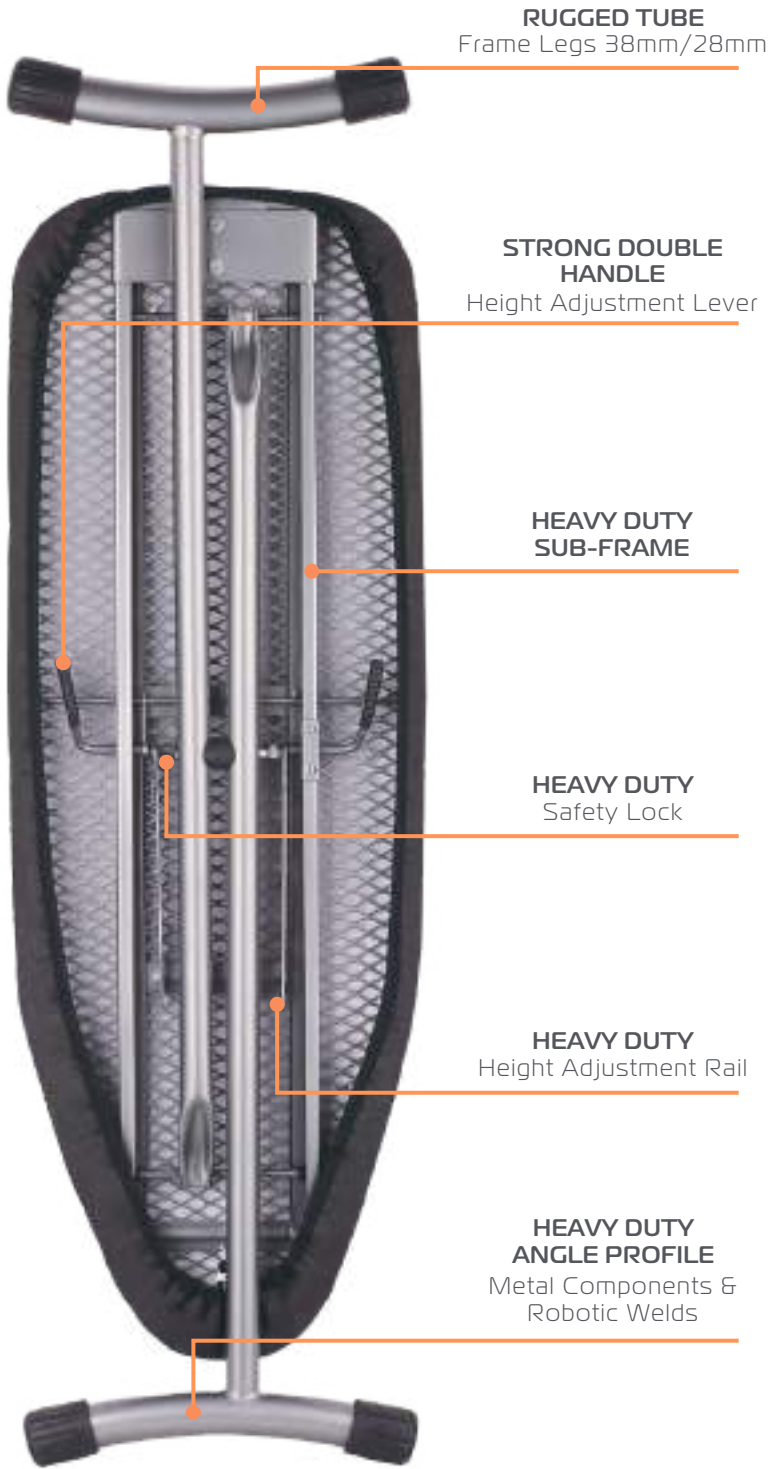

SHERINGTON
109(L) x 38(D) x 87(H)cm



ROTHWELL
116(L) x 33(D) x 76(H)cm



MOULTON
97(L) x 33(D) x 76(H)cm



Metallic Heat Reflective
Iron Board Cover



Smooth Bound Edges
to Avoid Fraying



2mm foam & 5mm felt
Combination Padding



Steam Flow
Metal Mesh Top



New Generation
Ironing Centres Safety & Storage

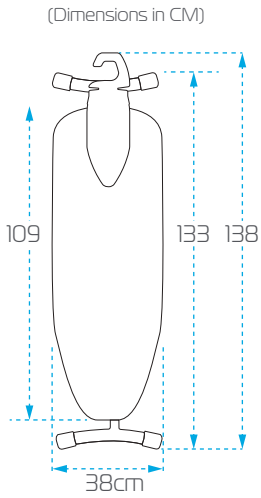

SHERINGTON
Full Size Ironing Board

BROMHAM
Ironing Centre



DEENE + YARDLEY
1200W Dry Iron

OR

KINGSMEAD
Ironing Centre



CHORLEY + HERTFORD
1600W Steam Iron

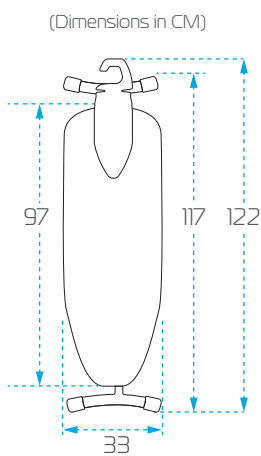

MOULTON
Compact Size Ironing Board

ELSTOW
Ironing Centre



DEENE + YARDLEY
1200W Dry Iron

OR

STAGSDEN
Ironing Centre



CHORLEY + HERTFORD
1600W Steam Iron





Wall mounted



Rapid cable tidy slot. Cables can be bundled and inserted to save time



Integrated cable wrap Stores neatly



Optional holder To mount ironing board

Stroud Ironing Centre

SAFE. ROBUST. CONVENIENT.
PATENTED DESIGN

- ➔ Unique and Patented Design – sliding frame design secures iron
- ➔ Convenient, Easy and Safe – swivel, lift out & replace during ironing
- ➔ Universal Fitting - Suits and fits almost all iron types and sizes
- ➔ Protective Silicon Pad protects soleplate



84mm Adjustments



360° swivel



Protective silicon pad to prevent soleplate damage and absorb heat

Design Protected by International Registered Designs & Patents Pending © Emberton Group Inc





Heat resistant pad to prevent soleplate damage and absorbs heat



Integrated cable wrap. Cables can be neatly wrapped around frame



Holder Angle matches iron shape for Perfect Fit



Rapid cable tidy slot. Cables can be gathered and inserted directly in slot to save time



Optional J Hook to hang ironing board

Somerton

Universal Iron & Iron Board Storage

SECURES IRON TO PREVENT FALLING HAZARD UNIQUE & PATENTED

- ➔ Convenient, Easy & Safe - Easy lift in and lift out with frame design to prevent falling hazard
- ➔ Universal Fitting - Fits almost all iron types and sizes
- ➔ Soft Coated Protective Quality Steel Frame - protects iron from scratches and damage

Dimensions

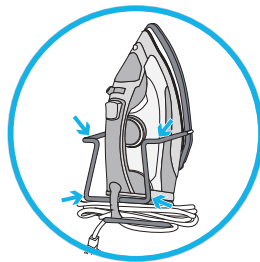
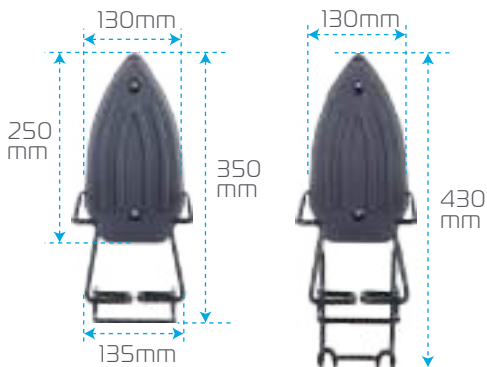

Z Shape Frame Prevents Iron Falling Hazard



Design Protected by International Registered Designs & Patents Pending © Emberton Group Inc





Secure & safe to prevent falling



Open Rail Sandhurst available



Sandhurst

Universal Iron Board Holder & Store

- ➔ Unique and Patented Design Instant & Easy to Fit
- ➔ Ultimate safety – specially designed U frame safely secures iron board to prevent falling out
- ➔ Universal – Suits all sizes of T Leg Ironing Boards
- ➔ Easy to remove and replace ironing board
- ➔ Fits regular door or wall hooks
- ➔ Stores iron board neatly on rail
- ➔ Robust & Rigid - Strong welded joints with welded plate centre
- ➔ Thick 5mm steel and strong welded plate for years of trouble free use
- ➔ Durable NON slip finish to hold iron board securely in place
- ➔ Durable rubberized protective coating finish prolongs life of iron board frame and coating



Neat & tidy wardrobe storage

Specifications

Dimensions	65(W) x 126(H) x 62(D) mm
Material	5mm Steel with Welded Joints
Weight	27g



Stores Boards on Wall Hooks

Design Protected by International Registered Designs & Patents Pending © Emberton Group Inc





RECESS BOLT HOLES
for Flush Fitting Bolts



SPECIAL PROFILE
Keeps Board Clear of Wall

Hyde

Ironing Board Wall Holder

- ➔ Made of Heavy Duty Carbon Steel
- ➔ Durable Silver Powder Coated Finish
- ➔ Compact and Strong
- ➔ Recess Bolt Holes for Flush Fitting Bolts
- ➔ Mounts To The Wall To Store Ironing Board
- ➔ Stores Ironing Board neatly

Specifications

Dimensions	170(W) x 74(H) x 40 (D) mm
Material	Quality Carbon Steel
Weight	160g



Space Saving



Curved angle is a perfect match
for Tough Board frame





ACCESSORIES & ROOM ESSENTIALS

Bodmin

Multi-Function Alarm Clock with Wireless Charging & Speaker

- ➔ Built-in Latest Wireless Connection Technology & Able to Pair with Almost All Compatible Devices
- ➔ Highest Quality Speaker - 5 Wattage Full Frequency Loudspeaker each for Dynamic Audio
- ➔ Hassle-free Wireless Charger with Fast Charging Technology feature & Compatibles with Almost All Support Devices
- ➔ Available setting of Wireless pairing, Dual Alarm Clock setting, Snooze Alarm Mode, AUX Audio & FM Radio, TF Card and Double USB Port for wire-style pairing
- ➔ Ultra Large LCD Display with Anti-Scratch Screen, adjustable LCD Screen Brightness and Day, Time details display
- ➔ Back-up Clock Memory with 2x 1.5V AAA Batteries
- ➔ Optional USB Type-C Adaptor & Screw fixing point with Anti-Theft Cable
- ➔ Battery Slot with Secured Cover

Specifications

Power	AC 110 – 240V, 50-60Hz
Wireless Charger Wattage	10W
Battery (Optional)	2 x 1.5V AAA Batteries (NOT INCLUDED)
Dimensions	128mm (L) x 102mm (W) x 77mm (H)
Certification	CE, UKCA, FCC, ROHS & CCC Approved
Weight	0.45 Kg



Available Setting Options



Optional USB Type-C Adaptor



Optional Screw Type Anti-Theft Cable





Fast Charging Technology

Bodmin
Multi-Function Alarm Clock with
Wireless Charging & Speaker



ACCESSORIES & ROOM ESSENTIALS

Woburn

PUSHPOWER Digital Bathroom Scale

- ➔ BATTERY-FREE – powered by **PUSH POWER** Button
- ➔ 4 High Precision Sensors for Accurate Weight
- ➔ TOUGHENED SAFETY GLASS 8MM Thickness
- ➔ ULTRA LARGE LCD Display
- ➔ Modern, Elegant & Stylish Design
- ➔ Stable & Rigid Platform
- ➔ Overload & Error Indication
- ➔ Weight up to 180 kgs
- ➔ Auto Switch OFF
- ➔ Units in KGS & LBS

Specifications

Dimensions	310mm x 310mm x 30mm
Material	8mm Toughened Safety Glass
Certification	CE & RoHs
Weight	1.6 kg



Battery-Free
PUSH POWER Button



Ultra Large LCD Display



Available in BLACK



8mm Ultra-Tough Glass



Woburn
PUSHPOWER Digital Bathroom Scale



ACCESSORIES & ROOM ESSENTIALS

Fairford - Soft Grip Digital Bathroom Scale

- Unique & Patented Soft Grip Touch
- Improved Anti-Slip Performance
- 4 High Precision Sensors for Accurate Weight
- Toughened Safety Glass 8mm thickness
- Auto Switch ON/OFF Saves Battery Life
- Modern, Elegant & Stylish Design
- Weight range 5 to 180 kgs
- Overload & Error Indication
- Stable & Rigid Platform
- Units in KGS, LBS or STONES
- Low Battery Indicator

Specifications

Dimensions	300 x 300 x 22mm
Voltage	3V
Battery	2 x CR2032 Lithium Ion Batteries included
Material	8mm Toughened Safety Glass
Certification	CE & RoHS
Weight	1.94kg



Extra Large LCD Display
80 x 45mm

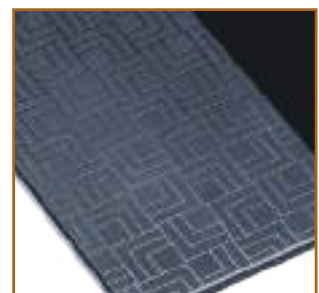

Improved Anti-slip
Performance



Stable & Rigid Platform



Fairford - Soft Grip -Black
Digital Bathroom Scale



Fairford - Soft Grip -White
Digital Bathroom Scale



Ashton Digital Bathroom Scale

- ➔ High Precision Sensors for accurate weight
- ➔ Auto ON & OFF
- ➔ Modern, Elegant & Stylish Design
- ➔ Weighs up to 180 kgs
- ➔ Stable & Rigid Platform
- ➔ Units in KGS & LBS

Specifications

Dimensions	300 x 300 x 24mm
Voltage	3V
Battery	2 x AAA Batteries included
Material	8mm Toughened Safety Glass
Certification	CE & RoHS
Weight	1.95kg



Toughened Safety Glass
8mm thickness



Wide LCD Display
75mm x 31mm



SPECIFICATIONS



SPECIFICATIONS - KETTLES



Model	Evesham - Steel / Black	Evesham - Steel / Black	Evesham - Black
Art No	EH50714 (EU Plug-EH Controller) EH50716 (EU Plug-Strix Controller)	EH50715 (UK Plug-EH Controller) EH50717 (UK Plug-Strix Controller)	EH50724 (EU Plug-EH Controller) EH50722 (EU Plug-Strix Controller)
Page	5	5	5
Power	220-240V, 50-60Hz	220-240V, 50-60Hz	220-240V, 50-60Hz
Wattage	1500-1800W	1500-1800W	1500-1800W
Capacity	1 Litre	1 Litre	1 Litre
DUAL SAFE	Yes	Yes	Yes
Material	Polypropylene High Grade SS304 Stainless Steel Body & Heat Plate Double Layer Safety Insulation	Polypropylene High Grade SS304 Stainless Steel Body & Heat Plate Double Layer Safety Insulation	Polypropylene High Grade SS304 Stainless Steel Body & Heat Plate Double Layer Safety Insulation
Overall Height	220mm	220mm	220mm
Top Diameter	88mm	88mm	88mm
Base Diameter	143mm	143mm	143mm
Weight	930g	930g	930g
Certification			
Mark/Warranty	8pcs - 69.5 x 20.7 x 44cm 9.6kg 0.0633CBM	8pcs - 69.5 x 20.7 x 44cm 9.6kg 0.0633CBM	8pcs - 69.5 x 20.7 x 44cm 9.6kg 0.0633CBM
Barcodes	EH50714 (EU Plug-EH Controller) EH50716 (EU Plug-Strix Controller) 	EH50715 (UK Plug-EH Controller) EH50717 (UK Plug-Strix Controller) 	EH50724 (EU Plug-EH Controller) EH50722 (EU Plug-Strix Controller)



Model	Evesham - Black	Malvern Brushed Stainless Steel	Malvern Black
Art No	EH50725 (UK Plug-EH Controller) EH50723 (UK Plug-Strix Controller)	EH50550 (EU Plug-EH Controller) EH50635 (EU Plug-Strix Controller) EH50634 (UK Plug-Strix Controller)	EH50726 (EU Plug-EH Controller) EH50643 (EU Plug-Strix Controller) EH50644 (UK Plug-Strix Controller)
Page	5	7	7
Power	220-240V, 50-60Hz	220-240V, 50-60 Hz	220-240V, 50-60 Hz
Wattage	1500-1800W	800-950W	800-950W
Capacity	1 Litre	0.5 Litre	0.5 Litre
DUAL SAFE	Yes	Yes	Yes
Material	Polypropylene High Grade SS304 Stainless Steel Body & Heat Plate Double Layer Safety Insulation	High Grade SS304 Stainless Steel Body & Heat Plate	High Grade SS304 Stainless Steel Body & Heat Plate
Overall Height	220mm	185mm	185mm
Top Diameter	88mm	90mm	90mm
Base Diameter	143mm	143mm	143mm
Weight	930g	770g	770g
Certification			
Mark/Warranty	8pcs - 69.5 x 20.7 x 44cm 9.6kg 0.0633CBM	12pcs - 52.5 x 39.5 x 38cm 11.82kg 0.079CBM	12pcs - 52.5 x 39.5 x 38cm 11.82kg 0.079CBM
Barcodes	EH50725 (UK Plug-EH Controller) EH50723 (UK Plug-Strix Controller) 	EH50550 (EU Plug-EH Controller) EH50635 (EU Plug-Strix Controller) EH50634 (UK Plug-Strix Controller) 	EH50726 (EU Plug-EH Controller) EH50643 (EU Plug-Strix Controller) EH50644 (UK Plug-Strix Controller)

SPECIFICATIONS - KETTLES



Model	Corsham Brushed Stainless Steel	Corsham Black	Corsham Black
Art No	EH50633 (EU Plug-EH Controller) EH50637 (EU Plug-Strix Controller) EH50636 (UK Plug-Strix Controller)	EH50705 (EU Plug-EH Controller) EH50729 (EU Plug-Strix Controller)	EH50709 (UK Plug-EH Controller) EH50728 (UK Plug-Strix Controller)
Page	8	8	8
Power	220-240V, 50-60 Hz	220-240V, 50-60 Hz	220-240V, 50-60 Hz
Wattage	800-950W	800-950W	800-950W
Capacity	1 Litre	1 Litre	1 Litre
DUAL SAFE	Yes	Yes	Yes
Material	High Grade SS304 Stainless Steel Body & Heat Plate	High Grade SS304 Stainless Steel Body & Heat Plate	High Grade SS304 Stainless Steel Body & Heat Plate
Overall Height	209mm	209mm	209mm
Top Diameter	90mm	90mm	90mm
Base Diameter	143mm	143mm	143mm
Weight	790g	790g	790g
Certification			
Mark/Warranty	12pcs - 52.5 x 39.5 x 43.0cm 12.5kg 0.089CBM	12pcs - 53.0 x 40.0 x 43.0cm 12.37kg 0.091CBM	12pcs - 53.0 x 40.0 x 43.0cm 12.37kg 0.091CBM
Packaging Details			
Barcodes	EH50633 (EU Plug-EH Controller) EH50637 (EU Plug-Strix Controller) EH50636 (UK Plug-Strix Controller) 	EH50705 (EU Plug-EH Controller) EH50729 (EU Plug-Strix Controller) 	EH50709 (UK Plug-EH Controller) EH50728 (UK Plug-Strix Controller)



Model	Guildford Black	Guildford White
Art No	EH50740 (EU Plug-EH Controller) EH50739 (UK Plug-Strix Controller)	EH50743 (EU Plug-EH Controller) EH50745 (UK Plug-EH Controller)
Page	9	9
Power	220-240V, 50-60Hz	220-240V, 50-60Hz
Wattage	870-1035W	870-1035W
Capacity	0.8 Litre	0.8 Litre
DUAL SAFE	No	No
Material	Plastic Body	Plastic Body
Overall Height	180mm	180mm
Top Diameter	90mm	90mm
Base Diameter	139mm	139mm
Weight	605g	605g
Certification		
Mark/Warranty	12pcs - 46.5 x 36.5 x 35cm 9.2kg 0.059CBM	12pcs - 46.5 x 36.5 x 35cm 9.2kg 0.059CBM
Packaging Details		
Barcodes	EH50740 (EU Plug-EH Controller) EH50739 (UK Plug-Strix Controller) 	EH50743 (EU Plug-EH Controller) EH50742 (UK Plug-EH Controller)

SPECIFICATIONS - WELCOME TRAYS



Model	Heywood Slate-Main Tray - Matt Black	Heywood Slate-Service Tray - Matt Black	Heywood Slate-Amenity Holder - Matt Black	Heywood Slate-Main Tray - Matt White
Art No	EH50557	EH50595	EH50596	EH50614
Page	11	11	11	11
Material	Melamine	Melamine	Melamine	Melamine
Cert Food Grade	Yes	Yes	Yes	Yes
Overall Length	35.8cm	23.5cm	14.5cm	35.8cm
Overall Width	25.8cm	11cm	7.5cm	25.8cm
Height	1.0cm	1.0cm	4cm	1.0cm
Weight	500g	135g	130g	500g
Certification Mark/Warranty				
Packaging Details	24pcs- 37.5 x 22 x 28cm 13.35kg 0.023CBM	24pcs- 25.5 x 22 x 13.5cm 3.76kg 0.008CBM	24pcs- 36 x 18 x 19.5cm 3.7kg 0.013CBM	24pcs- 37.5 x 22 x 28cm 13.35kg 0.023CBM
Barcodes	EH50557 	EH50595 	EH50596 	EH50614





Model	Heywood Slate-Service Tray - Matt White	Heywood Slate-Amenity Holder - Matt White	Halstead Black (Gloss)	Halstead White (Gloss)
Art No	EH50615	EH50616	EH50617	EH50618
Page	11	11	16	16
Material	Melamine	Melamine	Melamine	Melamine
Cert Food Grade	Yes	Yes	Yes	Yes
Overall Length	23.5cm	14.5cm	26.20cm	26.20cm
Overall Width	11cm	7.5cm	26.20cm	26.20cm
Height	1.0cm	4cm	3cm	3cm
Weight	135g	130g	610g	610g
Certification Mark/Warranty				
Packaging Details	24pcs- 25.5 x 22 x 13.5cm 3.76kg 0.008CBM	24pcs- 36 x 18 x 19.5cm 3.7kg 0.013CBM	12pcs- 41 x 29 x 28cm 9.05kg 0.033CBM	12pcs- 41 x 29 x 28cm 9.05kg 0.033CBM
Barcodes	EH50615 	EH50616 	EH50617 	EH50618



Model	Walton	Tongwell - Black	Tongwell - Mahogany	Tongwell - Natural
Art No	EH50175	EH50467	EH50468	EH50289
Page	15	14	14	14
Material	ABS	First Grade Bamboo	First Grade Bamboo	First Grade Bamboo
Cert Food Grade	Yes	Yes	Yes	Yes
Overall Length	46cm	26cm	26cm	26cm
Overall Width	22.5cm	26cm	26cm	26cm
Height	3.5cm	3cm	3cm	3cm
Weight	738g	850g	850g	850g
Certification Mark/Warranty				
Packaging Details	12pcs- 55 x 25 x 49cm 11.37kg 0.067CBM	12pcs- 49 x 28 x 28.2cm 11.81kg 0.039CBM	12pcs- 49 x 28 x 28.2cm 11.81kg 0.039CBM	12pcs- 49 x 28 x 28.2cm 11.81kg 0.039CBM
Barcodes	EH50175 	EH50467 	EH50468 	EH50289

SPECIFICATIONS - WELCOME TRAYS



Model	Cambourne Plus
Art No	EH50688
Page	13
Material	First Grade Bamboo
Cert Food Grade	Yes
Overall Length	27.0cm
Overall Width	19.4cm
Height	8.5cm
Weight	1450g
Certification	 
Mark/Warranty	
Packaging Details	12pcs- 57.6 x 28.7 x 42.2cm 17.10kg 0.0698CBM
Barcodes	EH50688 



SPECIFICATIONS - HAIRDRYERS



Model	Thames 2000W	Marlow-Curly Cable 1875W	Marlow-Straight Cable 1875W
Art No	EH50552 (EU Plug) EH50553 (UK Plug)	EH50689 (EU Plug) EH50690 (UK Plug)	EH50720 (EU Plug) EH50721 (UK Plug)
Page	17	21	21
Power	220-240V, 50-60 Hz	220-240V, 50-60 Hz	220-240V, 50-60 Hz
Wattage	1800-2200W	1800-2000W	1800-2000W
DUAL SAFE	Yes	Yes	Yes
Heat Setting	Two	Two	Two
Removable Filter	Yes	Yes	Yes
Steam Mesh Blade Cover	Yes	Yes	Yes
On /Off Press Switch	Yes	Yes	Yes
Thermostat Overheat Protection	Yes	Yes	Yes
Material	Polypropylene Ceramic Ionic	Polypropylene Ceramic coating with tourmaline	Polypropylene Ceramic coating with tourmaline
Cable length	Heavy Duty Coil Cable 350cm	Coil Cable 300cm	Straight Cable 250cm
Colour	Black	Black	Black
Dimensions	240 x 85 x 280mm	250 x 95 x 270mm	250 x 95 x 270mm
Weight	615g	695g	695g
Certification	 	 	 
Mark/ /Warranty			
Packaging Details	10pcs - 48.5 x 41.5 x 30cm 8.37kg 0.06CBM	10pcs - 46.5 x 27.5 x 31cm 8.07kg 0.04CBM	10pcs - 46.5 x 27.5 x 31cm 8.07kg 0.04CBM
Barcodes	EH50552 (EU Plug)  EH50553 (UK Plug) 	EH50689 (EU Plug)  EH50690 (UK Plug) 	EH50720 (EU Plug)  EH50721 (UK Plug) 

SPECIFICATIONS - HAIRDRYERS



Model	Salford Deluxe 1800W	Harrow Black 1600W	Harrow White 1600W
Art No	EH50532 (EU Plug) EH50533 (UK Plug)	EH50514 (EU Plug) EH50513 (UK Plug)	EH50539 (EU Plug) EH50540 (UK Plug)
Page	19	20	20
Power	220-240V, 50-60 Hz	220-240V, 50-60 Hz	220-240V, 50-60 Hz
Wattage	1800W	1400-1600W	1400-1600W
DUAL SAFE	Yes	Yes	Yes
Heat Setting	Two	Two	Two
Removable Filter	No	Yes	Yes
Steam Mesh Blade Cover	Yes	Yes	Yes
On /Off Press Switch	Yes	Yes	Yes
Thermostat Overheat Protection	Yes	Yes	Yes
Material	Luxurious soft touch finish with chrome	Plastic with luxury gloss finish	Plastic with luxury gloss finish
Cable length	Heavy Duty Coil 250cm	200cm	200cm
Colour	Black/Chrome	Black	White
Dimensions	240 x 90 x 250mm	140 x 77 x 231mm	140 x 77 x 231mm
Weight	600g	390g	390g
Certification			
Mark/Warranty	12pcs - 62.5 x 24 x 52.5cm 10.10kg 0.079CBM	20pcs - 47 x 27.5 x 45cm 11.50kg 0.058CBM	20pcs - 47 x 27.5 x 45cm 11.50kg 0.058CBM
Packaging Details			
Barcodes	 EH50532 (EU Plug) EH50533 (UK Plug)	 EH50514 (EU Plug) EH50513 (UK Plug)	 EH50539 (EU Plug) EH50540 (UK Plug)



Model	Mursley - Black	Mursley - White	Mursley - Chrome/ Black
Art No	EH50608	EH50609	EH50440
Page	23	23	23
Material	Silicon Inner Black Rubber - Outer	Silicon - Inner White Rubber - Outer	Silicon - Inner Plastic Chrome Rubber - Outer
Anti Theft	Yes	Yes	Yes
Suit Hard Wired Installation	Yes	Yes	Yes
Easy Mounting	Yes	Yes	Yes
Dimensions	93 x 74 x 50mm	93 x 74 x 50mm	93 x 74 x 50mm
Weight	45g	45g	50g
Packaging Details	200pcs- 90 x 32 x 45cm 16.4kg 0.13CBM	200pcs- 90 x 32 x 45cm 16.4kg 0.13CBM	200pcs- 90 x 32 x 45cm 16.63kg 0.13CBM
Barcodes	 EH50608	 EH50609	 EH50440

Model	Lathbury Hairdryer Bag
Art No	EH50357
Page	24
Material	Soft Velvet Silver Thread Embroidery Strong Black PP Drawstring
Colour	Black
Dimensions	400x 300mm
Weight	66g
Packaging Details	200pcs- 44 x 34.5 x 55cm 14kg 0.084CBM
Barcodes	 EH50357

SPECIFICATIONS - IRONS



Model	Croft - Steam Iron	Hertford Black - Steam Iron	Hertford White - Steam Iron
Art No	EH50682 (EU Plug) EH50683 (UK Plug)	EH50501 (EU Plug) EH50502 (UK Plug)	EH50546 (EU Plug) EH50547 (UK Plug)
Page	25	27	27
Power	220-240V, 50-60 Hz	220-240V, 50-60 Hz	220-240V, 50-60 Hz
Wattage	2000W	1600W	1600W
DUAL SAFE	Yes	Yes	Yes
Water Tank Capacity	300ml	250ml	250ml
Eco Auto Off Function	Yes	Yes	Yes
Anti Drip	Yes	Yes	Yes
Thermo Weld Technology	Yes	Yes	Yes
Smin Auto Off Function	Yes	Yes	Yes
Sole Plate Material	Ceramic	Non-Stick	Non-Stick
Cable	Heavy Duty 300cm	Heavy Duty 250cm	Heavy Duty 250cm
Colour	Black/Grey	Black/Grey	White/Grey
Plate size	220 x 120mm	206 x 113mm	206 x 113mm
Product size	284 x 122 x 142mm	266 x 120 x 140mm	266 x 120 x 140mm
Weight	1190g	982g	982g
Certification			
Mark/Warranty	8pcs - 55.8 x 31.9 x 35.8cm	10pcs - 62.5 x 30.5 x 32.5cm	10pcs - 62.5 x 30.5 x 32.5cm
Packaging Details	11.59kg 0.064CBM	11.70kg 0.062CBM	11.70kg 0.062CBM
Barcodes	EH50682 (EU Plug) EH50683 (UK Plug) 	EH50501 (EU Plug) EH50502 (UK Plug) 	EH50546 (EU Plug) EH50547 (UK Plug)



Model	Havant Deluxe - Steam Iron	Yardley - Dry Iron
Art No	EH50515 (UK Plug)	EH50548 (EU Plug) EH50549 (UK Plug)
Page	27	28
Power	220-240V, 50-60 Hz	220-240V, 50-60 Hz
Wattage	1600W	1200W
DUAL SAFE	Yes	Yes
Water Tank Capacity	250ml	No
Eco Auto Off Function	Yes	Yes
Anti Drip	Yes	Yes
Thermo Weld Technology	Yes	Yes
Smin Auto Off Function	Yes	Yes
Sole Plate Material	Non-Stick	Non-Stick
Cable	Heavy Duty 250cm	Heavy Duty 250cm
Colour	White/Grey	Black/Grey
Plate size	206 x 113mm	200 x 110mm
Product size	266 x 120 x 140mm	257 x 114 x 126mm
Weight	982g	745g
Certification		
Mark/Warranty	10pcs - 62.5 x 30.0 x 32.5cm	10pcs - 59.5 x 29 x 31cm
Packaging Details	11.5kg 0.0609CBM	9.22kg 0.054CBM
Barcodes	EH50515 (UK Plug) 	EH50548 (EU Plug) EH50549 (UK Plug)

SPECIFICATIONS - TOUGH IRONING BOARDS



Model	Sherington - Ironing Board Full Size	Moulton - Ironing Board Compact Size	Rothwell - Ironing Board Compact Size with Fixed Metal Rest
Art No	EH50379	EH50380	EH50383
Page	29	29	29
Material	Metal	Metal	Metal
Metal Mesh Top	Yes	Yes	Yes
Rugged Tube	Yes	Yes	Yes
Frame Legs 38mm/28mm	Yes	Yes	Yes
Suit Hard Wired	Yes	Yes	Yes
Cover Grey Metallic Fabric Colour	Yes	Yes	Yes
Underlay Plus Foam	Silver Grey Frame Grey Fabric Colour	Silver Grey Frame Grey Fabric Colour	Silver Grey Frame Grey Fabric Colour
Smooth Binding Edges	Yes	Yes	Yes
Pre fitted System to Attached Holders	Yes	Yes	Yes
Fixed Metal Rest	Yes	Yes	No
Warranty	No	No	Yes
Dimensions	109 x 38cm	97 x 33cm	116 x 33cm
Height	87cm	76cm	76cm
Folded Size	133 x 38 x 7cm	117 x 33 x 7cm	128 x 33 x 7cm
Packaging Details	4pcs- 135.5 x 35 x 42.5cm 23.15kg 0.202CBM	4pcs- 120.5 x 36 x 37.5cm 20.50kg 0.163CBM	4pcs- 131.5 x 35.5 x 38cm 21.55kg 0.177CBM
Barcodes	EH50379 	EH50380 	EH50383



Model	Stanion - Iron Board Cover Full Size	Warkton - Iron Board Cover Compact Size
Art No	EH50388	EH50387
Page	30	30
Material	100% Cotton, Coated Aluminium Surface, Foam & Polyester Underlay	100% Cotton, Coated Aluminium Surface, Foam & Polyester Underlay
Colour	Charcoal Grey	Charcoal Grey
Warranty		
Dimensions	109 x 38cm	97 x 33cm
Packaging Details	20pcs- 53 x 32 x 51.5cm 6.0kg 0.087CBM	20pcs- 53.5 x 33 x 41cm 5.5kg 0.072CBM
Barcodes	EH50388 	EH50387

SPECIFICATIONS - IRONING CENTRES SAFETY & STORAGE















Model	Kingsmead	Bromham
Art No	EH50428 (EU Plug) EH50429 (UK Plug)	EH50442 (EU Plug) EH50441 (UK Plug)
Page	32	32
Inclusions		
Ironing Board/Art No	Sherrington (Full Size) / EH50379	Sherrington (Full Size) / EH50379
Iron / Art No	Hertford Steam Iron 1600W / EH50501 (EU Plug) EH50502 (UK Plug)	Yardley Dry Iron 1200W / EH50548 (EU Plug) EH50549 (UK Plug)
Iron Holder/Art No	Chorley / EH50518	Deene / EH50398
Dimensions		
Board	109 x 38 x 87cm	109 x 38 x 87cm
Folded size without holder	133 x 38 x 7cm	133 x 38 x 7cm
Folded size with holder	144 x 38 x 7cm	144 x 38 x 7cm
Packaging Details		
Ironing Board	4pcs-135.5 x 35 x 42.5cm 23.15kg 0.202CBM	4pcs-135.5 x 35 x 42.5cm 23.15kg 0.202CBM
Hertford 1600W	10pcs-62.5 x 30.5 x 32.5cm 11.70kg 0.062CBM	
Iron Yardley 1200W		10pcs-59.5 x 29 x 31cm 9.22kg 0.053CBM
Holder Chorley	12pcs-87.5 x 41.7 x 33.7cm 15kg 0.123CBM	
Holder Deene		12pcs-42 x 43 x 54.5cm 14.60kg 0.098CBM
Warranty		
Barcodes		















Model	Stagsden	Elstow
Art No	EH50431 (EU Plug) EH50430 (UK Plug)	EH50444 (EU Plug) EH50443 (UK Plug)
Page	32	32
Inclusions		
Ironing Board/Art No	Moulton (Compact Size) / EH50380	Moulton (Compact Size) / EH50380
Iron / Art No	Hertford Steam Iron 1600W / EH50501 (EU Plug) EH50502 (UK Plug)	Yardley Dry Iron 1200W / EH50548 (EU Plug) EH50549 (UK Plug)
Iron Holder/Art No	Chorley / EH50518	Deene / EH50398
Dimensions		
Board	97 x 33 x 76cm	97 x 33 x 76cm
Folded size without holder	117 x 33 x 7cm	117 x 33 x 7cm
Folded size with holder	128 x 33 x 7cm	128 x 33 x 7cm
Packaging Details		
Ironing Board	4pcs-120.5 x 36 x 37.5cm 20.5kg 0.163CBM	4pcs-120.5 x 36 x 37.5cm 20.5kg 0.163CBM
Hertford 1600W	10pcs-62.5 x 30.5 x 32.5cm 11.70kg 0.062CBM	
Iron Yardley 1200W		10pcs-59.5 x 29 x 31cm 9.22kg 0.053CBM
Holder Chorley	12pcs-87.5 x 41.7 x 33.7cm 15kg 0.123CBM	
Holder Deene		12pcs-42 x 43 x 54.5cm 14.60kg 0.098CBM
Warranty		
Barcodes		

SPECIFICATIONS - IRONING CENTRES SAFETY & STORAGE



Model	Stroud - Iron Holder	Stroud - U Hook	Somerton - Iron Holder	Somerton - J Hook
Art No	EH50558	EH50563	EH50507	EH50708
Page	33	33	34	34
Material	Steel Double Non Slip Rubberized Protective Coating Finish	Steel	100% Cotton, Coated Aluminium Surface, Foam & Polyester Underlay	100% Cotton, Coated Aluminium Surface, Foam & Polyester Underlay
Colour	Grey	Grey	Charcoal Grey	Charcoal Grey
Certification Mark/Warranty	 	 	 	 
Dimensions	35.6 x 13.5 x 13cm	20.3 x 10.5 x 6.5cm	35 x 13.5 x 13cm	22 x 10.5 x 5.8cm
Weight	0.635kg	0.140kg	0.60kg	0.135kg
Packaging Details	12pcs- 60.7 x 43.4 x 36.9cm 9.74kg 0.0972CBM	100pcs- 67 x 27.8 x 24.5cm 14kg 0.046CBM	10set- 90.7 x 28.0 x 30.0cm 6.45kg 0.0762CBM	50pcs- 58.0 x 40.8 x 24.0cm 9.80kg 0.0568CBM
Barcodes	EH50558 	EH50563 	EH50507 	EH50708 



Model	Swivel Holder Bracket with Anti Theft Cable Lock	Sandhurst - Security Rail Loop	Sandhurst - Open Rail Hook	Hyde - Wall Bracket
Art No	EH50562	EH50566	EH50556	EH50508
Page	33	35	35	36
Material	Steel	Steel- Soft Touch Finish	Steel- Soft Touch Finish	Heavy Duty Carbon Steel Double Silver Powder Coated Finish
Colour	Grey	Grey	Grey	Grey
Certification Mark/Warranty	 	 	 	 
Dimensions	8.3 x 6 x 5.2cm	6.5 x 6.2 x 12.6cm	6.6 x 6.2 x 12.6cm	170 x 74mm
Weight	0.274kg	0.820kg	0.820kg	0.160kg
Packaging Details	100pcs- 52.5 x 34.5 x 15cm 30.4kg 0.0272CBM	100pcs- 47 x 20 x 30cm 9.6kg 0.0282CBM	100pcs- 47 x 20 x 30cm 10.0kg 0.0282CBM	100pcs- 70 x 19.5 x 17.5cm 18kg 0.024CBM
Barcodes	EH50562 	EH50566 	EH50556 	EH50508 

SPECIFICATIONS - ACCESSORIES & ROOM ESSENTIALS



Model	Bodmin - Multi-Function Alarm Clock with Wireless Charging & Speaker
Art No	EH50768-EU Plug/EH50769-UK Plug
Page	37
Power	AC 110 – 240V, 50-60Hz
Wattage	10W
Battery	2 x1.5V AAA Batteries (NOT INCLUDED)
Colour	Black
Material	ABS
Dimensions	128 x 102 x 77mm
Weight	0.45kg
Certification	
Mark/Warranty	
Packaging	18pcs- 43.2 x 36.8 x 36cm
Details	11.8kg 0.0572CBM
Barcodes	<div style="display: flex; justify-content: space-around;"> <div style="text-align: center;"> <p>EH50768 (EU Plug)</p> </div> <div style="text-align: center;"> <p>EH50769 (UK Plug)</p> </div> </div>



Model	Woburn - Push Power Digital Bathroom Scale
Art No	EH50753
Page	39
Power	PUSH POWER Button Battery Free
Capacity	5-180kg
Units	KG-LB
Colour	White
Material	Toughened Safety Glass Paltform
Dimensions	310 x 310 x 30mm 8mm Toughened Safety Glass
Weight	1.6kg
Certification	
Mark/Warranty	
Packaging	6pcs- 37.5 x 34.5 x 34.5cm
Details	14.50kg 0.0446CBM
Barcodes	<p>EH50753</p>



Model	Fairford - Soft Grip Digital Bathroom Scale	Fairford - Soft Grip Digital Bathroom Scale	Ashton Digital Bathroom Scale
Art No	EH50626	EH50627	EH50358
Page	41	42	43
Power	2xCR2032 Lithium Iron Battery Included	2xCR2032 Lithium Iron Battery Included	2xAAA Battery Included
Capacity	5-180kg	5-180kg	180kg
Units	KG-LB-ST	KG-LB-ST	KG-LB
Colour	Black	White	Black
Material	Non Slip Tempered Glass Paltform	Non Slip Tempered Glass Paltform	Tempered Glass Paltform
Dimensions	300 x 300 x 22mm 8mm Tempered Glass	300 x 300 x 22mm 8mm Tempered Glass	300 x 300 x 24mm 8mm Tempered Glass
Weight	1.94kg	1.94kg	1.95kg
Certification			
Mark/Warranty			
Packaging	4pcs- 35 x 20.5 x 35.5cm	4pcs- 35 x 20.5 x 35.5cm	6pcs- 33.8 x 31.4 x 34.9cm
Details	9.3kg 0.026CBM	9.3kg 0.026CBM	13.20kg 0.037CBM
Barcodes	<p>EH50626</p>	<p>EH50627</p>	<p>EH50358</p>



INTELLECTUAL PROPERTY
Patents & Registered Design



TOUGH BOARD - Rugged & Durable; We have combined a rugged frame with heavy duty metal components and robotic welds to withstand guests' tough use.



DUAL SAFE - an organic, thermo-sensitive material, remarkably sensitive to abnormally high temperatures. Upon sensing critical heat levels, DUAL SAFE activates and the electrical current will be interrupted immediately and permanently.



WATER TANK TECHNOLOGY - Special anti-fracture water tank welding technique ensures a permanent seal to prevent water leakage.

EMBERTON™

www.emberton.com
info@emberton.com